

# QK-G026 GSM Remote Controller

- AC motor remote control dialler

Features	Applications
<ul style="list-style-type: none"> <li>• Control AC motors (forward and reverse) via a toll free call</li> <li>• Uses caller ID for identification, unknown callers will be ignored</li> <li>• Dual working modes, namely “Dead Man” and time pulsed</li> <li>• Alternating or fixed direction setting via SMS</li> <li>• Easy to install and configure (no PC required)</li> <li>• Up to 4 Mobile Phones per Unit</li> <li>• Request Status via SMS</li> <li>• Compatible with all major GSM SIM networks</li> <li>• Tri-band GSM for use in Europe &amp; USA</li> </ul>	<ul style="list-style-type: none"> <li>• Electric doors, shutters, garages</li> <li>• Electronic curtains/blinds</li> <li>• AC motors, actuators</li> <li>• Plant maintenance</li> <li>• Valve control</li> <li>• Pumping stations</li> <li>• Oil/gas pipeline control</li> <li>• Security system</li> <li>• PLCs and automation system</li> </ul>

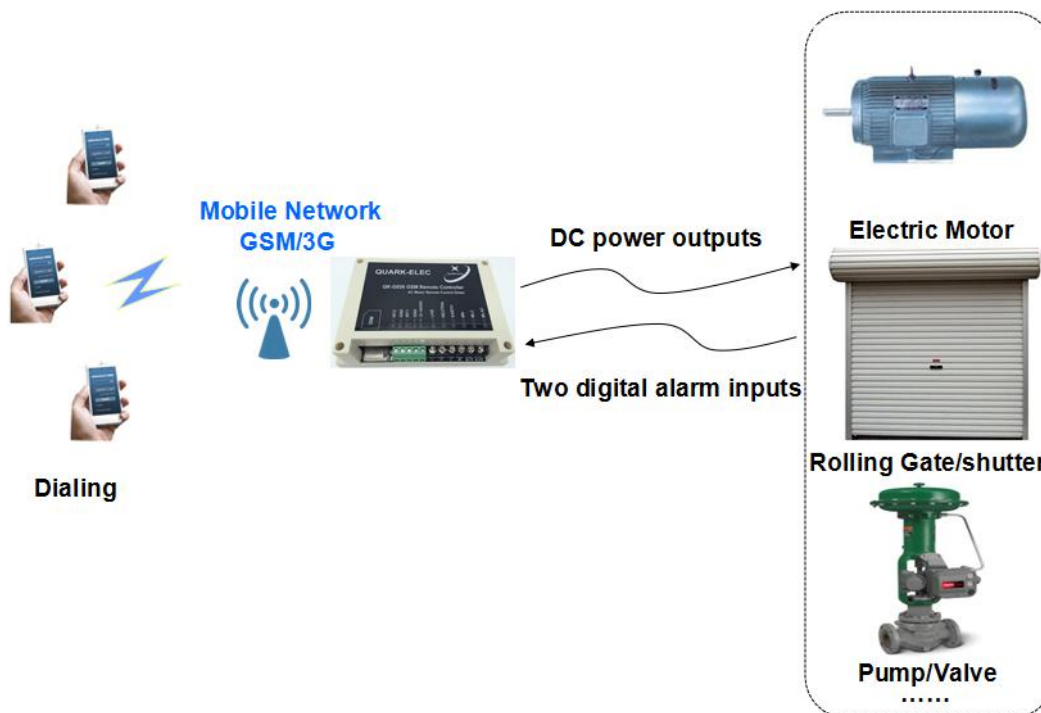



## Document history

1.0	14-04-2015	Initial release
1.1	3-05-2015	Minor document changes

## Order Information

Part No	Description
QK-G026	GSM Remote Controller (AC motor control) module
QK-G026S	QK-G026 GSM AC Motor Remote Controller with enclosure

## CONTENTS

<b>1</b>	<b>INTRODUCTION.....</b>	<b>3</b>
<b>2</b>	<b>PREPARING SIM CARD.....</b>	<b>4</b>
<b>3</b>	<b>HARDWARE.....</b>	<b>5</b>
3.1	MODULE.....	5

3.2	POWER CONNECTIONS.....	7
3.3	ALARM FUNCTION AND DIGITAL INPUT CONNECTION.....	7
3.4	SIM CARD SLOT.....	9
3.5	ENCLOSURE.....	9
<b>4</b>	<b>CONFIGURATION.....</b>	<b>11</b>
<b>5</b>	<b>COMMAND AND RESPONSE SMS.....</b>	<b>11</b>
<b>6</b>	<b>OPERATING SPECIFICATIONS.....</b>	<b>14</b>

## **1 INTRODUCTION**

QK-G026 module is an industrial grade product intended to provide remote control of AC motors or any AC powered devices.

It allows operators to control remote equipment and machines via a free call through the GSM network. Up to four mobile phone numbers (SIM card numbers) can be registered with the device and these mobile phones can belong to families/ technicians or engineers who have a requirement to control remote devices. Simply dialling from the registered SIM cards will allow barriers/doors to be opened or closed or machines to be turned on or off. There are no call costs since the GSM control module will not answer the call but will immediately take the necessary action after identifying the registered SIM card numbers.

- Dial from mobile phones to control remotely, no call fees charged.
- Four control mobile phones, one main control terminal and up to 3 additional control terminals can be registered with QK-G026.
- Two digital alarm inputs whereby various sensors can be monitored, e.g., photocell receivers, obstacle detectors, position sensitive detectors, motion sensors, temperature/wind detectors, carbon dioxide detectors and water leak detectors.
- The DC motor output can be set as “Dead Man” mode (activation during dialling period) or pulsed time mode (activation time is set as a fixed time).
- The DC motor output can be either fixed polarity or alternating polarity
- SIM “kept alive” all the time by sending a status SMS on pre-set days (between 28 and 99 days)

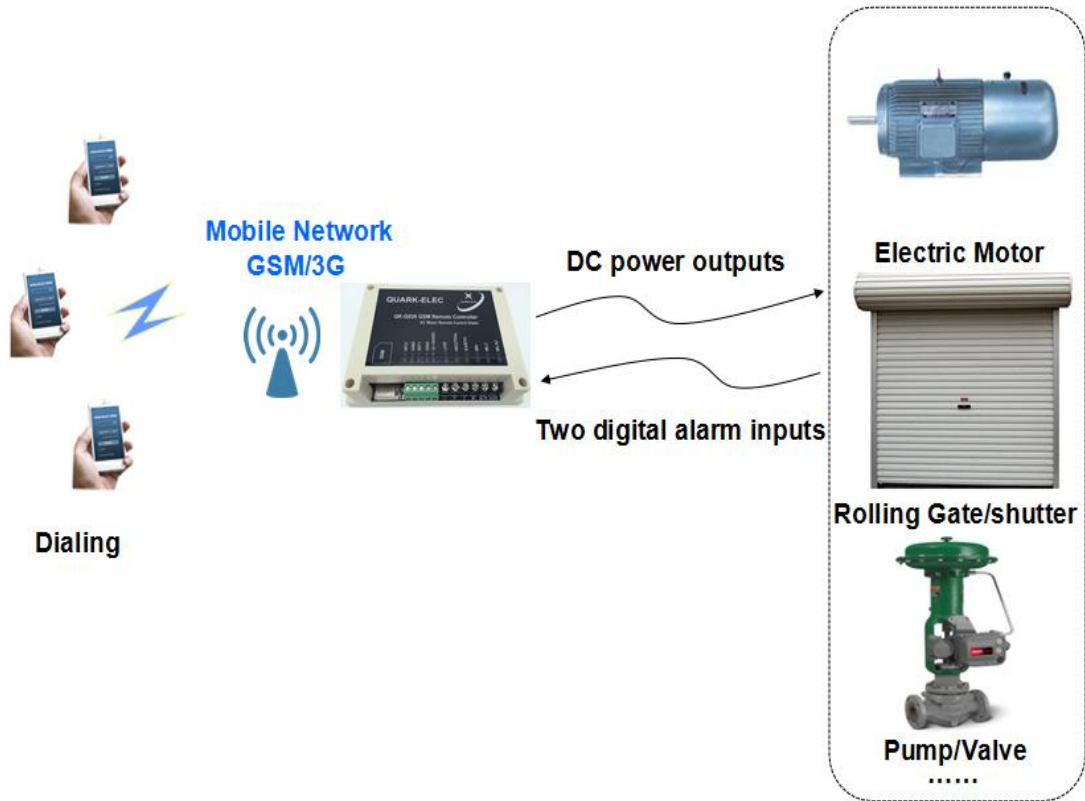

Figure 1 System diagram

## 2 PREPARING THE SIM CARD

All new SIM cards have to be registered with the network provider before they can be used, usually by calling the network provider or by registering online. Please refer to the instructions supplied with your SIM card.

After successfully registering the SIM card, please ensure that there is sufficient credit on the card for confirmation texts to be sent from QK-G026 module. The PIN request should be disabled from the SIM card before inserting it into QK-G026 module. To check the PIN request status of your SIM card, place the card in an unlocked mobile phone and switch the phone on. If a call can be made without entering a PIN number, then the PIN request is disabled.

Lastly, please disable any voicemail that is set up on the SIM card and retain the caller ID function available. The SIM card is now ready to use.

If a 'pay as you go' (PAYG) SIM card is being used it is recommended that users choose to automatically 'Top-Up' when the credit on the card falls below a certain limit. Some PAYG SIM cards will be deactivated by the network if they are not used to make an outgoing voice call or to send an SMS text message within a specific period. To prevent this simply, use the set alive SIM message (SIMALIVEnn) to prevent the SIM card being de-activated.

### 3 HARDWARE

#### 3.1 Module

A general view of the module is shown below and details of each function are provided in the next sections.

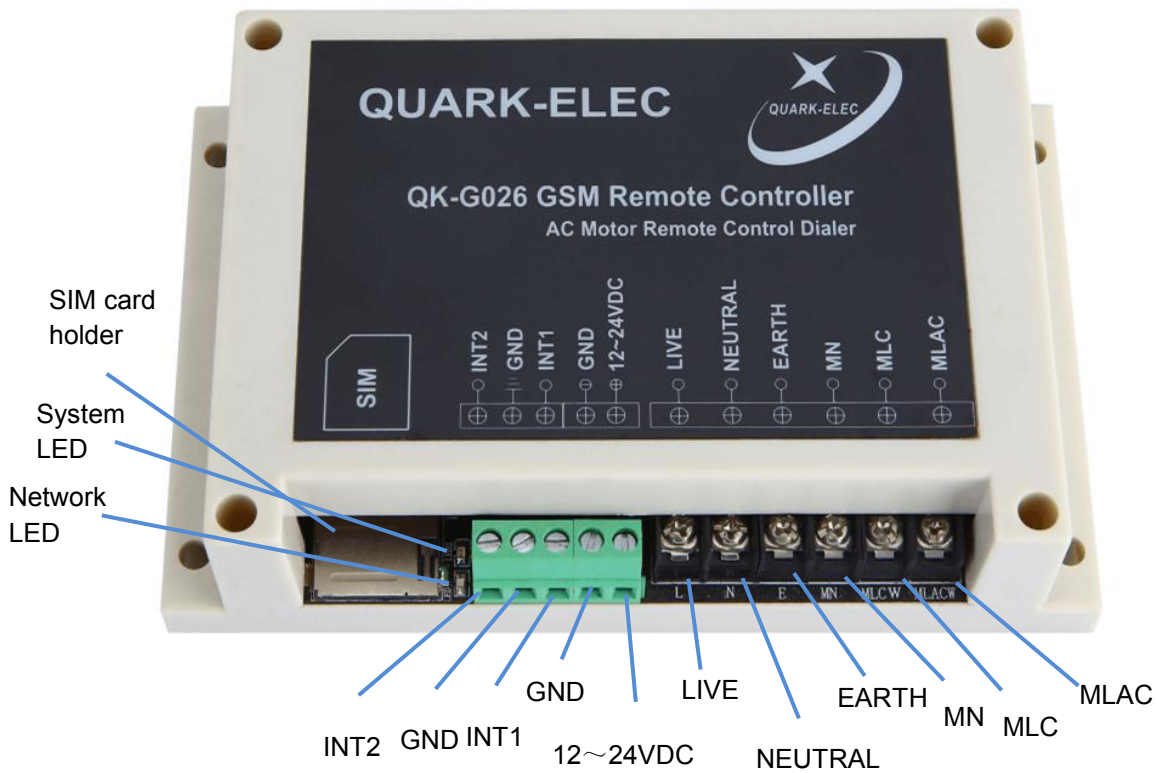

Figure 2 General view of the control module (V1.0)

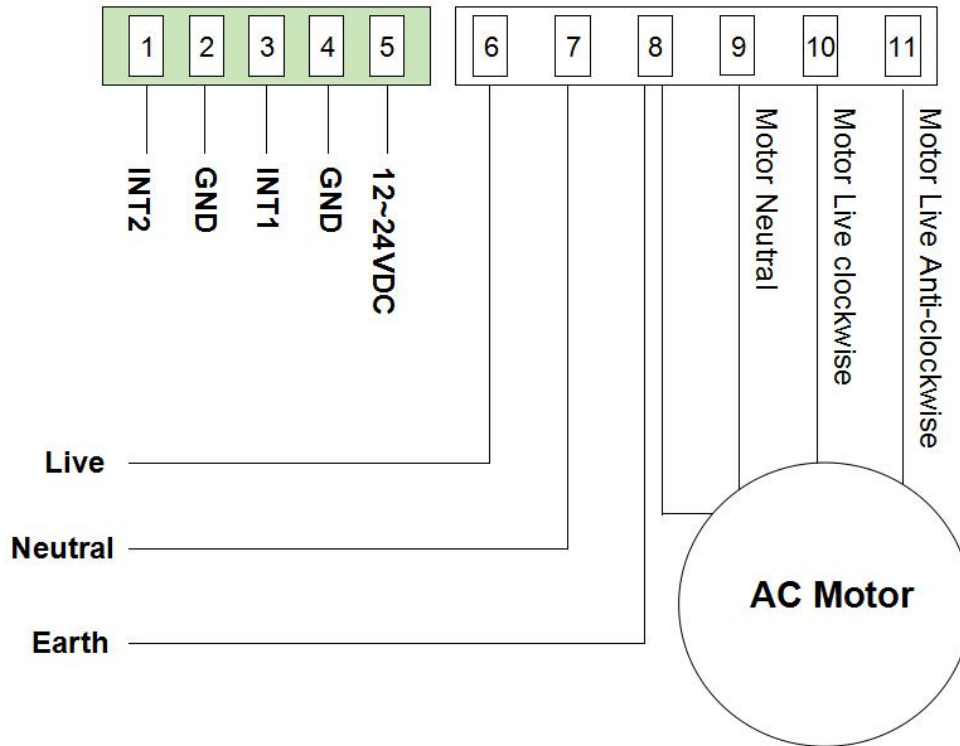

Figure 3 Input/output connections

1	INT2	External alarm input
2	GND	
3	INT1	
4	GND	12-12VDC input
5	12~24VDC	
6	Live	220/230VAC power supply * Earth terminal is shared with the earth on the motor side.
7	Neutral	
8	*Earth	
9	MN	Motor 220/230V AC
10	MLC	
11	MLAC	

Figure 4QK-G026 Connection details

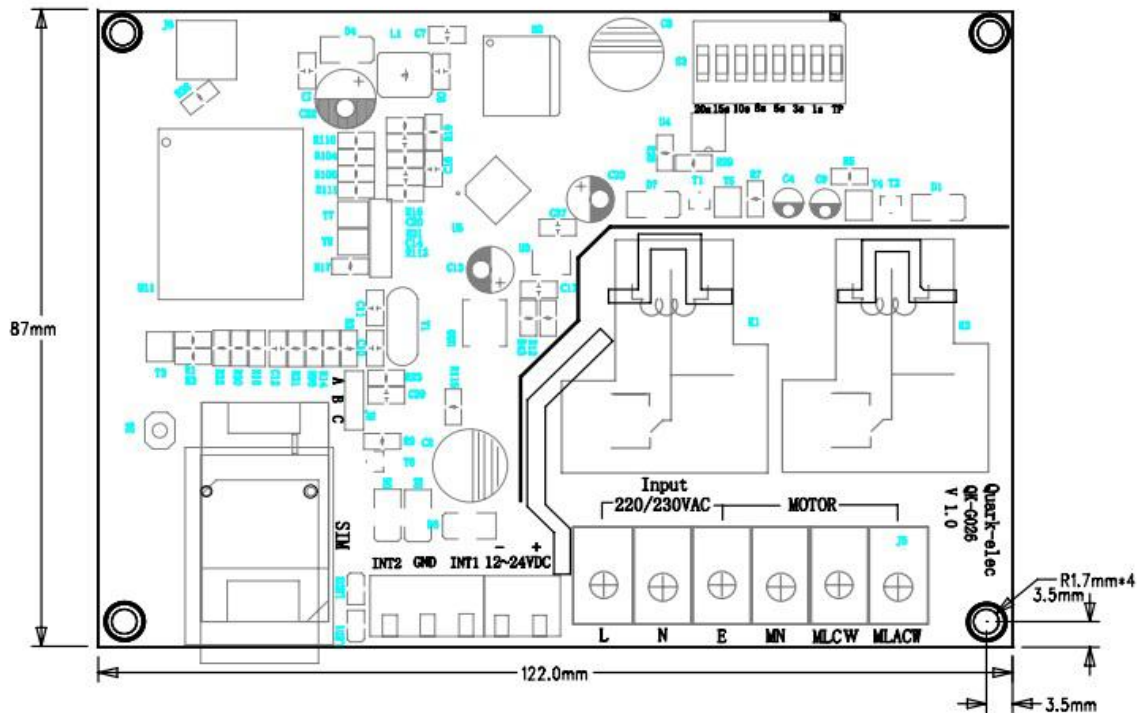

Figure 5QK-G026 mechanical drawing (V1.1)

### 3.2 Power connections

The QK-G026 module can be powered by 12V to 24VDC. Connect a 12VDC power supply (or above, up to 24V) to the power screw terminals and the red power LED will flash at 1 second intervals once the system has finished initialisation. The blue network LED indicator will initially flash quickly and once logged onto the network it will flash more slowly (approximately once every 3 to 4 seconds).

### 3.3 Alarm function and digital input connection

QK-G026 has two external monitoring/alarm input connectors and various sensors can be connected, such as photocell receivers, obstacle detectors, position sensitive detectors, motion sensors, temperature/wind detectors, carbon dioxide detectors and water leak detectors.

In the event of any of these connected sensor/detectors being triggered and sending a low level signal (0V) to QK-G026, QK-G026 will disable the output of P1 and P2 immediately.

There are two typical ways to connect the external alarm inputs to QK-G026 – the external alarm device can be used either as a switch or as an input source for INT1/INT2 on the QK-G026 module.

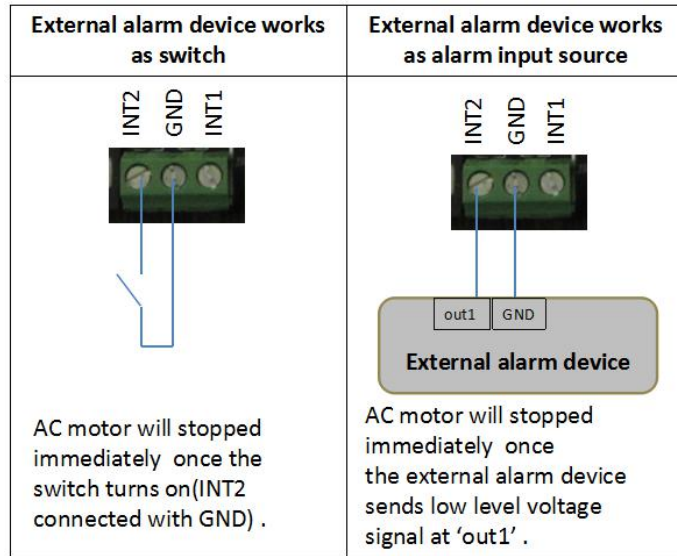

Figure 6 External alarm device connecting methods

Below is a typical alarm input connection drawing where QK-G026 is used to control roller shutters:

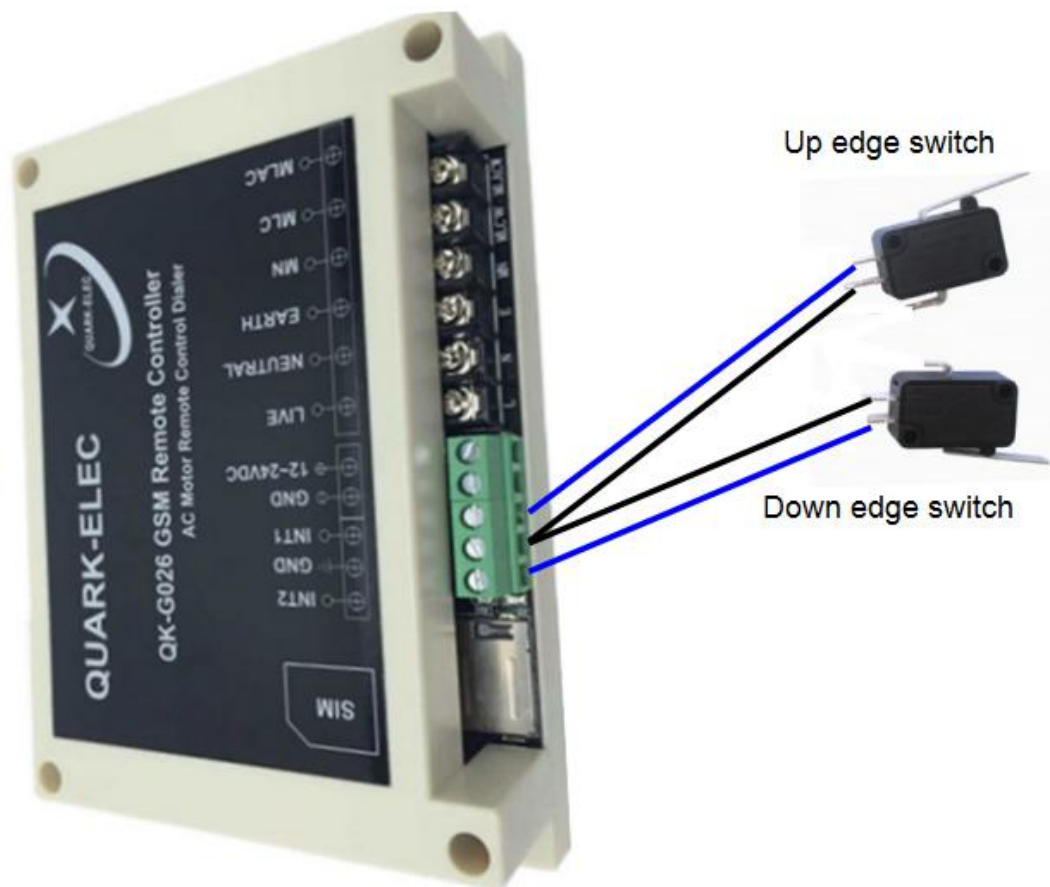

Figure 7 Typical connections used on a roller shutter



### 3.4 SIM card slot

The GSM SIM card should be inserted into the SIM card slot before switching the power on. Most 3V SIM cards can work with the QK-G026 module and registering can take up to few minutes after the device has been powered up. The network LED flashes at 1Hz after registration is completed.

### 3.5 Enclosure

An IP56 Insulation Class 2 plastic enclosure, with 145 x 90 x 41mm external dimensions is used for QK-G026.

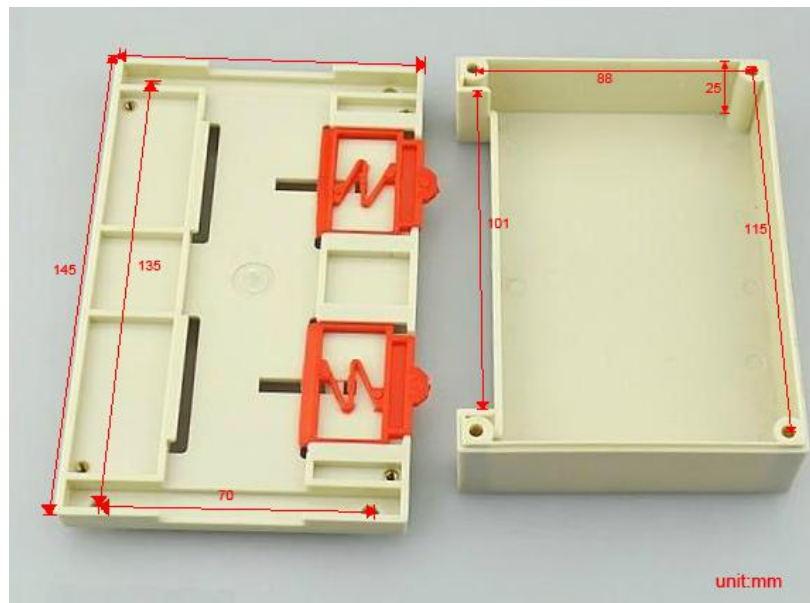

Figure 8 Enclosure drawing



Figure 9 QK-G026 (with enclosure)



Figure 10 QK-G026 (with enclosure) back view

## 4 CONFIGURATION

The following is required to configure QK-G026 for first time use:

- Insert the SIM card into the controller box.
- Power up and wait for the blue LED to flash slowly. Depends on the network situation, this normally takes about 1 to 2 minutes.
- Send '888888' as an SMS to QK-G026 controller and, if successful, the user should receive 'Thanks for using Quark-elec products. Your main phone has been registered'.
- If additional mobile terminals are required send 'BDn(mobile terminal number)F' to QK-G026 controller. Up to 3 additional terminals can be configured in this way. The operator can use the main terminal to register, delete and check additional SIM card numbers. The QK-G026 controller will verify the incoming numbers and, if they are in the registered SIM numbers, it will execute the actions.
- QK-G026 supports two working modes, namely "Dead Man" and pulsed time. When operating in pulsed time mode, the AC motor outputs are active for a fixed setting time and then they stop. When operating in "Dead Man" mode, the unit will maintain the active status until the call is terminated. For each mode, QK-G026 can be set to three different polarities, corresponding to three the different running directions of a AC motor:
  1. clockwise
  2. anti-clockwise
  3. alternating direction
- If the module was set to work in pulsed time mode, please ensure that the working time has been set.

By now, QK-G026 is ready for use. Details about the SMS commands and response SMS messages can be found in the next section.

## 5 COMMAND AND RESPONSE SMS







Remember that all SMS text commands must always be sent using CAPITAL letters. Do NOT add spaces or any other characters in the SMS.

Function	Command	Note
<b>Register SIM cards</b>		
Register myself as main SIM number	888888	Register the main mobile terminal with QK-G026 module by sending '888888' to QK-G026 model.  If registration is successful the module will reply with 'Thanks for using Quark-elec products. Your main phone has been registered.' Each QK-G026 module can

## Quark-Elec application note

		only have one main registered SIM card number.
Register additional SIM numbers	BDn(mobile number)F n=1 for 1st mobile terminal n=2 for 2nd mobile terminal n=3 for 3 <sup>rd</sup> mobile terminal	Once the main mobile terminal is registered with QK-G026, another three mobile terminals can be paired with QK-026.  For example, by sending BD107919157124F, the first mobile terminal (number is 07919157124) has been paired with QK-025. Similarly, BD207909135124F, pairs QK-G026 with the second terminal (number is 07909135124).  If the n mobile terminal is successfully paired, the message 'Your No n phone has been registered' will be returned by QK-G026,
Delete additional SIM numbers	DELn n=1 for 1 <sup>st</sup> mobile terminal n=2 for 2 <sup>nd</sup> mobile terminal n=3 for 3 <sup>rd</sup> mobile terminal	The registered SIM cards can be deleted from the authorised SIM list by sending DELn. Once deleted, the SIM terminals can no longer control QK-G026.
Check registered SIM numbers	WHORED	QK-G026 will reply with the authorised SIM list in the following format:  No.1 SIM is xxxxxxxx; No.2 SIM is xxxxxxxx; No.3 SIM is xxxxxxxx.
<b>Switching relay &amp; mode checking</b>		
Set alive time (keep SIM alive text)	SIMALIVEnn  Where $28 \leq nn \leq 99$ . Any input number outside of this range means this function will not operate.  The factory default setting is SIMALIVE00, which means this function is disabled.	QK-G026 will reply with the authorized SIM list in the following format:  QK-G026 will send a heart beat SMS message every nn days.

## Quark-Elec application note

Set the working mode in Dead Man mode	 DMM: Dead Man mode (alternating direction)	<p>QK-G026 will reply with the authorised SIM list in the following format:</p> <p>QK-G026 has been set to operate in Dead Man mode (Alternating/ fixed clockwise/ fixed anti-clockwise direction).</p>
	 CLM: Dead Man mode (fixed clockwise direction)	
	 ANM: Dead Man mode (fixed anti-clockwise direction)	
Set the working mode in Pulsed Time mode	 PTM: Pulsed Time mode (alternating direction)	<p>QK-G026 will reply with the authorised SIM list in the following format:</p> <p>QK-G026 has been set to operate in Pulsed Time mode (alternating/fixed clockwise/fixed anti-clockwise direction).</p>
	 GZY: Pulsed Time mode (fixed clockwise direction)	
	 GFY: Pulsed Time mode (fixed anti-clockwise direction)	
Set the working time in pulsed time mode	PTDnn Where $03 \leq nn \leq 99$ .	<p>QK-G026 will reply with the relay state information in the following format:</p> <p>QK-G026 is working in pulsed time mode and the setting time is nn seconds.</p>
Check relay working mode	RMODE	<p>QK-G026 will reply with the relay's working mode information in the following format:</p> <p>QK-G026 is working in xx (xx means one of the six modes which has been setup).</p>
<b>Monitoring/alarm input</b>		
<p>QK-G026 has two digital input ports which can be used to monitor external signals. These input ports accept 0V to 5V voltage levels. In the case of any of the input voltage levels being below 1.0V, the AC motor output will be disabled.</p>		

## 6 OPERATING SPECIFICATIONS

Item	Specification
Frequency bands	Quad-band: GSM850, EGSM 900, DCS1800, PCS1900.
SMS	MT, MO, CB, Test and PDU mode
Operating temperature	-25°C to +80°C
Storage temperature	-40°C to +85°C
DC supply	12 to 24VDC
Average supply current (typical quiescent)	40mA
Maximum supply current (during SMS transceiver activity)	550mA
GSM receive sensitivity	-107dBm
GSM transmitting power	Class 4(2W) at GSM850, EGSM 900. Class 1(1W) at ACS1800, PCS1900.
AC motor output voltage	220 to 240VAC
AC motor output maximum current	30A

## Quark-Elec application note

---

For more technical information and enquiries please go to the Quark-elec forum at:

<https://quark-elec.com/forum/>

For sales and purchasing information, please email us at: [info@quark-elec.com](mailto:info@quark-elec.com)



Quark-elec (UK)

Unit 7, The Quadrant  
Newark Close  
Royston, UK  
SG8 5HL